



## SPECIFICS

- #4 Brushed finish
- 18GA Stainless Steel #304 Alloy
- Finish direction parallel with drink rail length

## INSTALLATION

1. Cut drink rail Item #DR-HEM sections to length (if necessary).
2. Apply adhesive to the bar top or counter substrate.
3. Adhere the first section of the drink rail section to the surface.
4. Insert joint connector Item #DR-HEM-JC into the end of the secured section of the drink rail to connect additional sections or inside corner piece Item #DR-HEM-IC.
5. Seal the top of any seams with a mildew resistant clear silicone sealer.
6. Apply adhesive and add End Cap Item #DR-HEM-RC or DR-HEM-LC as needed.

**CUSTOM FINISHING  
AVAILABLE BY REQUEST**

## OVERHEAD VIEW

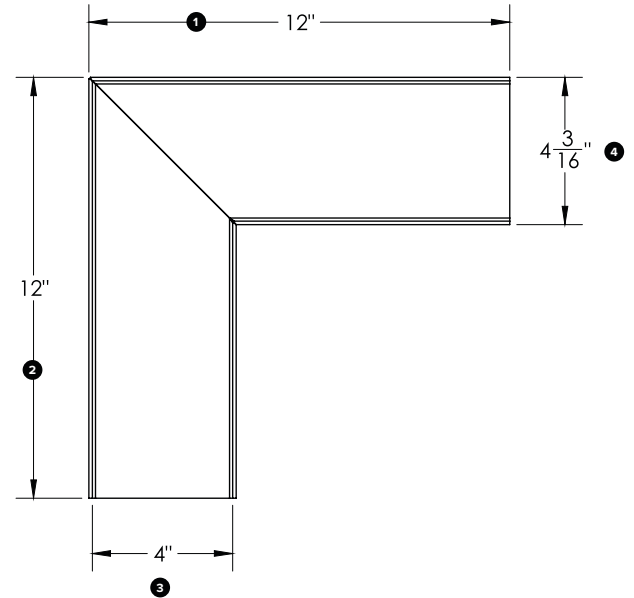

## ISOMETRIC VIEW

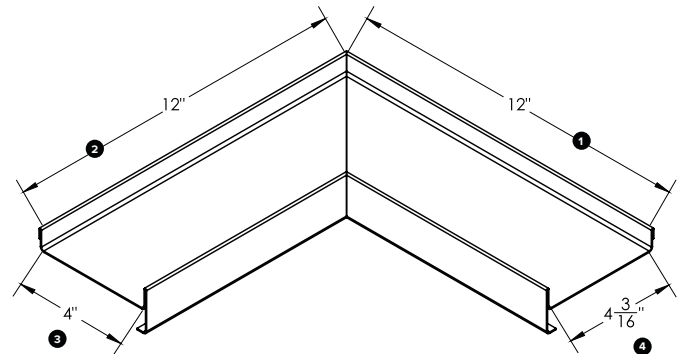

## DIMENSIONS

① LEFT BACK LENGTH	12"
② RIGHT BACK LENGTH	12"
③ INSIDE WIDTH	4"
④ OUTSIDE WIDTH	4 <sup>3</sup> / <sub>16</sub> "